



# ORGAN NEEDLES

CATALOGUE

ミシン針総合カタログ



Sewing Machine Needles

ミシン針総合カタログ



## Measuring points

Symbols of each dimension are as follows. The basic three dimensions (A, D and N) are indicated with each system our catalogue.

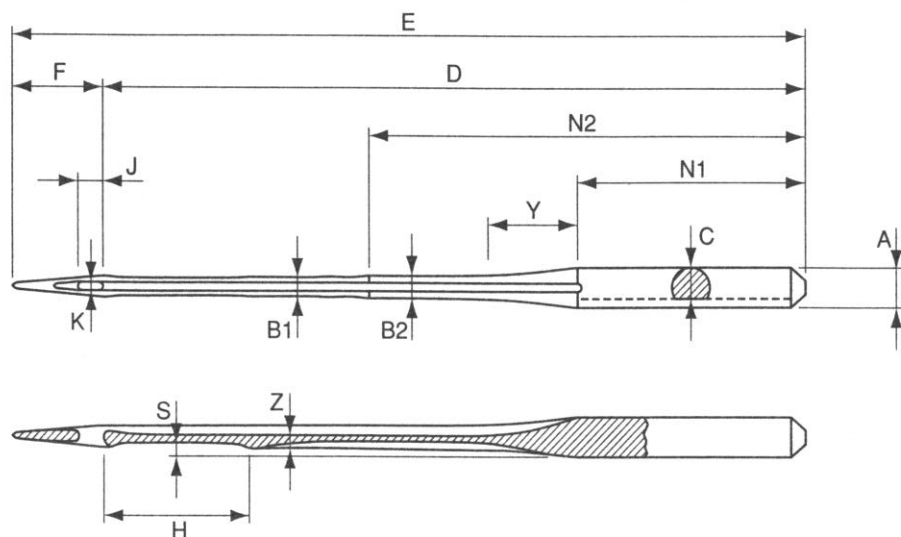

### Explanation of the measuring points

- A : Shank diameter
- B : Blade diameter
- D : Butt to eye length
- E : Total length
- F : Distance from end of eye to tip
- S : Depth of scarf
- H : Length of scarf
- J : Length of eye
- K : Eye width
- N : Length of shank
- Z : Depth of groove
- Y : Length of tapered part

### 主要部位記号

- A : 軸(シャンク)径
- B : 幹径
- D : 穴上寸法
- E : 全長
- F : 穴先寸法
- S : エグリ深さ
- H : エグリ長さ
- J : 穴縦寸法
- K : 穴横寸法
- N : 軸寸法
- Z : 溝深さ
- Y : テーパー部寸法

## 主要寸法

ミシン針の主要な部位を表す記号と名称は以下の通りです。本カタログ内の各種別の紹介欄に、ミシン針で最も主要な寸法 (A, D及びN) が記載されています。

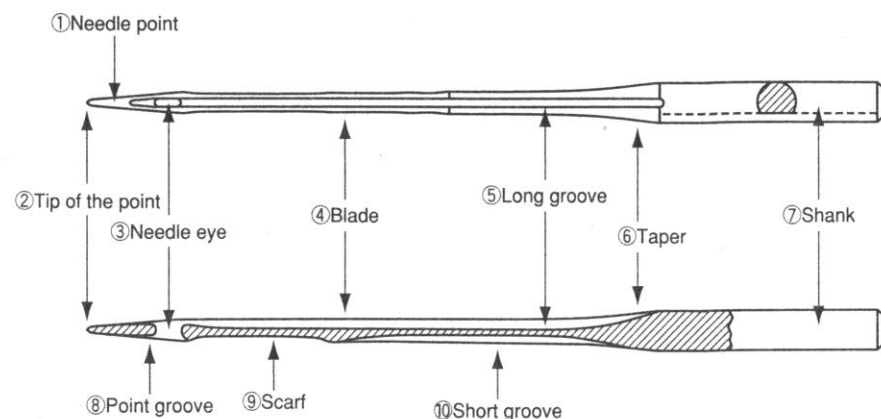

### Explanation of the main parts

- ① Needle point
- ② Tip of the point
- ③ Needle eye
- ④ Blade
- ⑤ Long groove
- ⑥ Taper
- ⑦ Shank
- ⑧ Point groove
- ⑨ Scarf
- ⑩ Short groove

### 主要部位名称

- ① 針先
- ② 先端
- ③ 糸穴
- ④ 針幹
- ⑤ 表溝
- ⑥ テーパー部
- ⑦ シャンク・軸
- ⑧ 短溝
- ⑨ エグリ
- ⑩ 裏溝

## Interrelation Table between Sewing Thread and Needle Size (Nm) 糸と針の関係表(番手)

糸種類 Thread Type 糸番手 Thread Size (Nm)	Cotton 綿糸	Silk 絹糸	Polyester Spun ポリエステルスパン	Vinylon ビニロン	Polyester Filament ポリエステル フィラメント	Nylon Filament ナイロン フィラメント	Nylon MonoFilament ナイロン モノフィラメント	Bicomponent Fiber 複合糸	Core Spun コア・スパン	Embroidery Thread 刺繍糸	Thread Type 糸種類
											糸番手 Thread Size (Nm)
Needle Size 針番手											
180							4 ~ 6				180
120	7 ~ 9		6 ~ 8		6 ~ 8				6 ~ 8		120
110							6 ~ 8				110
100	7 ~ 10	4 ~ 6	7 ~ 9		7 ~ 9	7 ~ 9			7 ~ 9	8 ~ 10	100
90		6 ~ 8						7 ~ 9			90
80	9 ~ 11	7 ~ 9	8 ~ 10		8 ~ 10	8 ~ 10	7 ~ 9	8 ~ 10	8 ~ 10	9 ~ 11	80
75									9 ~ 11		75
70	10 ~ 12	8 ~ 10	9 ~ 11				8 ~ 10				70
60	11 ~ 14	9 ~ 11	10 ~ 12		9 ~ 11	9 ~ 11	9 ~ 11	10 ~ 12	10 ~ 12	11 ~ 14	60
50	12 ~ 16	10 ~ 12	11 ~ 14	18 ~ 21	10 ~ 12	10 ~ 12	10 ~ 12	11 ~ 14	11 ~ 14	12 ~ 16	50
40	14 ~ 18	11 ~ 14	12 ~ 16		11 ~ 14	11 ~ 14	11 ~ 14	12 ~ 16	12 ~ 16	14 ~ 18	40
30	18 ~ 21	12 ~ 16	16 ~ 19	21 ~ 23	14 ~ 18	16 ~ 19	12 ~ 16	16 ~ 19	16 ~ 19	18 ~ 21	30
25										19 ~ 22	25
20	19 ~ 22	14 ~ 18	18 ~ 21	22½ ~ 24	16 ~ 19	18 ~ 21	14 ~ 18		18 ~ 21	21 ~ 23	20
15									19 ~ 22		15
10		16 ~ 19			19 ~ 22						10
8	22½ ~ 24		21 ~ 23	23 ~ 25	21 ~ 23				21 ~ 23	22½ ~ 24	8
6	23 ~ 25		22½ ~ 24	25 ~ 26							6
5			23 ~ 25		22½ ~ 24				23 ~ 25	22½ ~ 24	5
1					23 ~ 25						1
0											0

## Interrelation Table between Sewing Thread and Needle Size (Denier)

### 糸と針の関係表(デニール)

糸種類 Thread Type 糸番手 Thread Size (Denier)	Nylon MonoFilament ナイロン モノフィラメント	Embroidery Thread 刺繍糸、レーヨン	Needle Size 針番手	
50	4 ~ 6			
60				
75		8 ~ 10		
80	6 ~ 8			
110	7 ~ 9			
120		9 ~ 11		
130	8 ~ 10			
150	9 ~ 11			
180	10 ~ 12			
200		11 ~ 14		
230	11 ~ 14			
250				
300	12 ~ 16			
450	14 ~ 18			

### Japanese Ticket No. 呼び番手の表

Commonly Called No. 呼び	Cotton 綿糸	Polyester Spun ポリエステルスパン	Polyester Filament ポリエステルフィラメント	Nylon Filament ナイロンフィラメント
120	7	7		
100	7 ~ 8	7 ~ 8	7	7 ~ 9
80	7 ~ 11	7 ~ 9	7 ~ 9	7 ~ 10
60	8 ~ 14	8 ~ 12	7 ~ 10	7 ~ 11
50	10 ~ 16	10 ~ 14	8 ~ 12	9 ~ 14
40	14 ~ 19	12 ~ 18	11 ~ 16	11 ~ 14
30	16 ~ 21	14 ~ 19	14 ~ 20	16 ~ 19
20	19 ~ 23	19 ~ 23	18 ~ 22	18 ~ 21
10	20 ~ 23	20 ~ 23	19 ~ 23	
8	22 ~ 24	22 ~ 24	21 ~ 24	
5			24 ~ 25	
1				
0				

Comparison Table of Equivalent Sizes 針番手比較表

Organ —Singer—	3	4	5	6	7	8	9	10	11	12	13	14	15	16	17	18	19	20	21	22	22½	23	23½	24	25	26	27	28	29	30	31	32	32½	
German (metric)	35	40	45	50	55	60	65	70	75	80	85	90	95	100	105	110	120	125	130	140	150	160	170	180	200	230	250	280	300	330	350	380	400	
Union Special					022		025	027	<sup>029</sup> / <sub>030</sub>	032	034	036	038	040	042	044	<sup>047</sup> / <sub>048</sub>	049		054	060		067	078	<sup>079</sup> / <sub>080</sub>	090	100	110	120		140		156	
Columbia U.S.251								0	1	1½	2	2½	3	3½		4		4½	5	5½														
Columbia U.S.251 LG								5	10	15	20	25	30	35	40	45	50																	
Lewis					1½	2	2½		3			3½	4		4½	5			5½	6			7											
Marrow					000	00	0	1		2		3		4		5	6		7		8		9		10									
Reece								000		00		0		1		2	3		4	5														
Willcox & Gibbs—old no.						00	0	1		2		3		4		5	6		7	8	9	10												
Willcox & Gibbs—new no.					22	24	25	27	30	32		36		40		44	48	49	52															
Willcox & Gibbs—flatlock						1	1½	2		3		4																						
459 R (EBx1567)	22	21	20	19	18	17	16	15	14	13		12		11		10	9		8	7	6													
854S (Schiffli) 854 110S L83								00		0		1		2		3			4	5		6	7											

Size numbers of Sewing machine needles in each country:

\* Size numbering method of Organ and Singer is same.

As each measuring point is different, Organ(in case of being made for high-speed sewing)is slightly thinner.

\* German size numbers show the figures of sizes in MM. Union Special shows the figures of sizes in mills.





\* As the denotations for old German size numbers(0.00, ½,25 etc)are different by each maker, they cannot be indicated in the above conversion table, please enquire us in each case.

## Point designs of our sewing machine needles

Point types of Organ sewing machine needles are classified into the following types according to their uses. We show the point styles in side view and cutting designs in threading direction for all fabrics including synthetic and elastic materials and cutting designs for all leather materials as follows.

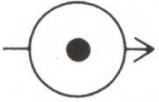
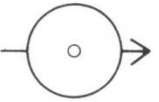
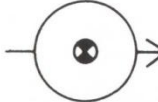
## ミシン針の針先形状及び先端形状

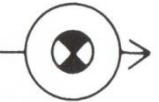
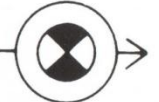
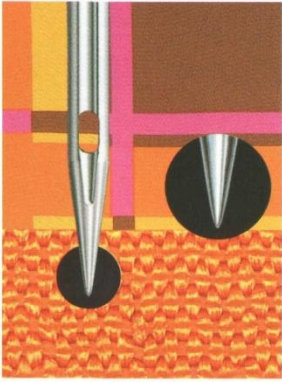
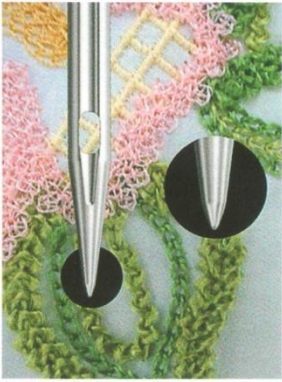
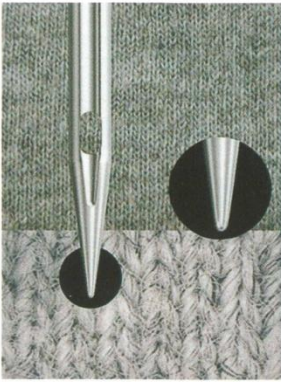
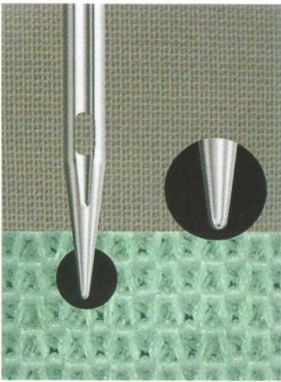
ミシン針の針先形状及び先端形状は、用途により以下のように大別されます。縫製条件に適した形状をお選び下さい。

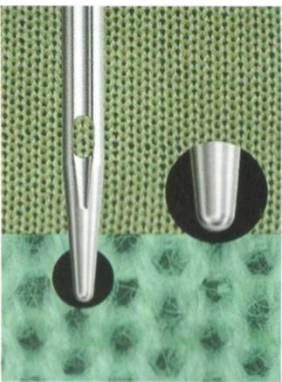
Point designs in threading direction 先端形状						
Side views 針先略図						
Organ designations オルガン記号	R	Q	J	B	U	Y
Other companies' designations 他社記号	R, SET	RG	SES, FFG, L BALL, SIN, R-K, NYR, BPL	SUK, FG, M BALL, SI R-KB, LAC, BMP	STR, TR, H BALL, KAL, BPH	SKF, G, EH BALL, BIL
Description 特徴	Normal round point 正規型	Extra light ball point Qボール	Light ball point Jボール	Medium ball point Bボール	Heavy ball point Uボール	Extra heavy ball point Yボール

Point designs in threading direction 先端形状			
Side views 針先略図			
Organ designations オルガン記号	S	TRI	SPI
Other companies' designations 他社記号		SD1, TRI TIP	RS, S SET
Description 特徴	Slim point スリム	Light Triangular point 小三角型	Slim set point 尖頭細身型

※ Slim Point has slimmer taper from the needle eye to the tip of the needle point and has a J-ball / SES Ball Point. Best suited for light knit fabrics.

スリムポイントの針先端部はJボールで、糸穴から先端までの針先の形状は通常よりも細身になっています。

Point designs in threading direction 先端形状				
Side views 針先略図				
Stitches 縫い目				
Organ designations オルガン記号	P	LR	LL	S
Other companies' designations 他社記号	W, NW	RTW, NRTW	TW, NTW	CR, NCR

Side views 針先略図	Point positions in threading direction 先端形状	Organ designations オルガン記号	Other companies' designations 他社記号	Description 特 徴
		EM	R-E0°, LG G ECC SET, SEM, EXEM	Long groove eccentric round point 上偏芯
		EK	R-E180°, SH G ECC SET, SEK, EXEK	Short groove eccentric round point 下偏芯
		EL	R-E270°, LF G ECC SET, SEL, EXEL	Left eccentric round point 左偏芯
		ER	R-E90°, RT G ECC SET, SER, EXER	Right eccentric round point 右偏芯
		CL	CL	Left twist groove at point 左溝ひねり
		CR	CR	Right twist groove at point 右溝ひねり
		HR		Half round point ハーフポイント
		HO		Hook point needle フック

Point designs in threading direction 先端形状	Organ designations オルガン記号	Other companies' designations 他社記号	Description 特 徴	Point designs in threading direction 先端形状	Organ designations オルガン記号	Other companies' designations 他社記号	Description 特 徴
	LBR	WD R TW	Extra wide reverse twist point 皮革用 45° 逆ひねり、大		SS		Narrow cross point 皮革用 横メス、小
	DI	DIA	Diamond point 皮革用 クロスダイヤ		D	TRI	Triangular point 三角型
	VR	R TWSP, NRTWSP	Reverse twist spear point 皮革用 45° 逆ひねり		SQ	QVK	Square point 四角型
	PCL		Narrow wedge point with left twist groove 皮革用 縦メス、溝左ひねり		TQ	QR, RSQ	Twist square point 45° ひねり四角型
	PCR		Narrow wedge point with right twist groove 皮革用 縦メス、溝右ひねり		V	STAY, SP W	Stay point 縦ステイ型
	LLCR		Twist point with right twist groove 皮革用 45° ひねり、溝右ひねり		CV		Cross stay point 横ステイ型
	PS		Narrow wedge point 皮革用 縦細メス、小				

## ORGAN NEEDLE SURFACE TREATMENT LINE UP

We provide various optional surface treatment for your sewing conditions.  
 Select the treatment type from below for your material and sewing conditions.  
 ※ Only HP treatment, the standard point style of needle under the size 14 is J ball point.

## 表面処理オプションのご紹介

縫製条件に合わせて様々な表面処理オプションをご用意しています。  
 使用例を参考にお選びください。  
 ※ HPのみ#14番以下の針では、先端はJボールポイントが標準仕様となっています。

### HP Trouble by Needle Temperature 針熱トラブル



### Trouble by Adhesion 粘着トラブル LP



Suitable for	ご使用例
Business suit	スーツ
Nylon jacket	ジャケット
Sportswear	スポーツウェア
Jeans	ジーンズ
Coat	コート
Rain coat	レインコート

Suitable for	ご使用例
Shirt	ワイシャツ
Business suit	スーツ
Synthetic leather pants	合成皮革のパンツ
Down jacket	ダウンジャケット
Sportswear	スポーツウェア
Jeans	ジーンズ
Car seat	自動車シート
Leather bag	革カバン
Air bag	エアバッグ

### PD Trouble by Wearing of Needle 摩耗トラブル



Suitable for	ご使用例
Jeans	ジーンズ
Belt	ベルト
Sportswear	スポーツウェア
Shoes, Leather shoes	靴・革靴
Leather Apparel	皮革衣料
Car seat	自動車シート

※ For further information, please contact Organ distributor. ※ 詳しくは取り扱い店へお問い合わせください。



NEEDLE SYSTEM 針記号	ORGAN SYSTEM オルガン記号	NEEDLE SYSTEM 針記号	ORGAN SYSTEM オルガン記号	NEEDLE SYSTEM 針記号	ORGAN SYSTEM オルガン記号	NEEDLE SYSTEM 針記号	ORGAN SYSTEM オルガン記号	NEEDLE SYSTEM 針記号	ORGAN SYSTEM オルガン記号
7×1	DY×1	16×73	PF×34R TF×1	29-C150	CP×1	35M	SM×35M	81	LA×81
7×2DIA	DY×2DIA	16×74NW	PF×34P	29-C-151	CP×12	48.5	EB×2	81×1	DC×1
7×2NTW	DY×2	16×75	SL×75	29-C-151X	CP×12	48.51	EB×1	81×5	DC×5
7×3	DY×3	16×87	TB×1	29-C-300	LW×3T LW×4T	52×5	PV×5	81LR	LA×81LR
7×3KF	DY×3KF	16×95	DB×95	29-C-300LG	LW×5T	52×7	PV×7	82×1	DM×1
7×4RTW	DY×2LR	16×99	TF×99	29-CA	LW×3T LW×4T	55×3	KJ×3	82×13	DM×13
7×4TW	DY×3LL	16×230NRTW	DB×F2	29-CB	LW×5T	58×1	NQ×1	88	DU×1
7×23	DY×23	16×231	DB×1	29-DEA	CP×1	60M	MR-R9	88×1	DA×1 DA×9
7×94LR	DY×3LR	16×257	DB×1	29-DHA	CP×12	61B	DP×1	88×9	DA×1 DA×9
14SP	AE×14SP	16×259	DJ×259	29-DHB	CP×12	62×21	UY×121 DV×1	88HK	LA×88
15×1	HA×1	23×1	DG×1	29-L	TQ×7	62×40SP	DV×40SP	88LL	DU×2
15×1H	HA×1	24×1	DH×1	29-LSS	TQ×9	62×43	DV×43	88LR	DU×2LR
15×2NTW	HA×1LL	25×3	TK×3	29-S	TQ×1	62×47	DV×47	92×1	DN×1 UY×143GS
15×2RTW	HA×1LR	29×1	DI×3	31×1	FV×1	62×53	TV×5	94×5	NB×5
16×1	PF×34R TF×1	29×3	DI×3	34	PF×34R	62×57	DV×57	108×1	BQ×1
16×2NCR	TF×F8	29×4NTW	DI×4	34CL	PF×34CL	62×59	DV×59	108×3	BQ×3
16×2NRTW	TF×2LR	29×4NW	DI×4LR	34D	TF×2D	64	TV×64 WG×64	110	SM×854B
16×2NTW	TF×2	29×4RTW	DI×4LR	34LL	TF×2	64B	TK×3	110(R)	PF×133R
16×2NW	PF×34P	29-34	LW×2T LW×6T	34LLCR	PF×34LLCR	68×3	LQ×3	110S	SH×3
16×2RTW	TF×2LR	29-39	LW-C5	34LR	TF×2LR	68×5	LQ×5	110S TOP	SH-110S TOP
16×3	PF×34CL	29-49	LW×2T LW×6T	34P	PF×34P	68×7	LQ×7	124×2	DR×2
16×4	TF×4	29-BA	LW×2T LW×6T	34PCL	TF×4	71×1	DL×1	124×2STAY	DR×2
16×5	DB×95	29-BC	LW×1T	34PCR	TF×6	71L	LA×71EL	124×4	DR×4 UO×1970
16×6	TF×6	29-BD	LW×1T	34(R)	PF×34R TF×1	71R	LA×71ER	126×1	FO×3
16×6NTW	PF×34LLCR	29-BK	LW-C5	34S	TF×F8	75×1SA	TT×81	126×9	FO×9
16×63	TF×63	29-BL	LW×2T LW×6T	35 : 18	DC×5	75W	LA×1617	128×1	TI×3

NEEDLE SYSTEM 針記号	ORGAN SYSTEM オルガン記号	NEEDLE SYSTEM 針記号	ORGAN SYSTEM オルガン記号	NEEDLE SYSTEM 針記号	ORGAN SYSTEM オルガン記号	NEEDLE SYSTEM 針記号	ORGAN SYSTEM オルガン記号	NEEDLE SYSTEM 針記号	ORGAN SYSTEM オルガン記号
128×2	TI×2	134-35P	DP×35P	134S	PF×134KS	135×17	DP×17	151×23	UY×8454
128×3	TI×3	134-35S	DP×35S	134SUK	SG×1907	135×17 SERV2	DP-K48	151S	CP×12
128×6DIA	TI×6	134-35VR	DP×35VR	134VR	PF×134VR	135×25	DP×25	175	DU×1
128×6TRI	TI×2	134CL	PF×134CL	135	TI×3	135×35LBALL	SG×1963	175×1	TQ×1
128×13	TI×3	134CR	PF×134CR	135×1	DP×1	135×39	DP×39	175×3	TQ×3
128×15	TI×15	134D	PF×134D	135×2	DP×1LL	135×53	SG×1906	175×7	TQ×7
128×21	TI×21	134DI	DP×8	135×5	DP×5 DP×7 DP×134	135×53MBALL	SG×1965	175×7KK	TQ-N14
129×1	EE×1	134DIA	DP×8	135×5M	SG×1907	135×65	DP×5	175×7SS	TQ-N14
130×3	DF×3	134EL	PF×134EL	135×5 M BALL	SG×1907	135D	TI×2	175×9	TQ×9
130×5	DF×5	134ER	PF×134ER	135×5MDAII	SG×1907	137×1	PH×1	175×13	TQ×13
130/705H	HA×130	134K	PF×797	135×6NW	PF×134P	137×1SM	PH×1SM	175H	US×175H
130/705HLL	HA×1LL	134KK	PF×134KK	135×7	DP×5 DP×7 DP×134	141×1	AV×1	175LR	DU×2LR
130/705HLR	HA×130LR	134KKD	PF×134KKD	135×8	PF×134LR	142×5	DO×5	190	MT×190
130B	DB×130B	134KKLR	PF×134KKLR	135×8DIA	DP×8	149×1	TV×1	190(R)	MT×190
130D	HA×1DE	134KKPCL	PF×134KKPCL	135×8NCR	PF×134KS	149×3	TV×3	190K	MT×190K
130LL	HA×1LL	134KKS	DP-F22	135×8NRSP	PF×134KS	149×5	TV×5	190LR	MT×190LR
130LR	HA×130LR	134LBR	PF×134LBR	135×8NRTW	PF×134LR	149×7	TV×7	206×15	HA×1
133(R)	PF×133R	134LL	PF×134LL	135×8NTW	PF×134LL	149×25	TV×25	214×1	DD×1
134×1	YS×1	134LLCR	PF×134LLCR	135×8NW	PF×134P	149×S25	TV×25	214×2NCR	DD×2S
134-35(R)	DP×35R	134LR	PF×134LR	135×8TRI	PF×134D	150	CP×1	214×2NRSP	DD×2S
134-35CL	DP×35CL	134P	PF×134P	135×8TW	PF×134LL	150×1	YM×1	214×2NRTW	DD×2LR
134-35CR	DP×35CR	134PCL	PF×134PCL	135×9	PF×797	151	CP×12	214×2NTW	DD×2
134-35D	DP×35D	134PCR	PF×134PCR	135×11	DP×5 DP×7 DP×134	151×1	TL×1	214×2RTW	DD×2LR
134-35K	DP×35K	134PCRS	PF×134PCR	135×16NTW	DP×16N	151×5	TL×5	214×2TW	DD×2
134-35LL	DP×35LL	134R	DP×5 DP×7 DP×134	135×16NW	DP×16	151×7	TL×7	215AH	LA×215
134-35LR	DP×35LR	134(R)	DP×5 DP×7 DP×134	135×16TW	DP×16N	151×21	UY×154GAS	216×1	CY×1











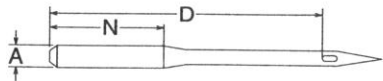

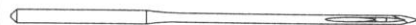















NEEDLE SYSTEM 針記号	ORGAN SYSTEM オルガン記号	NEEDLE SYSTEM 針記号	ORGAN SYSTEM オルガン記号	NEEDLE SYSTEM 針記号	ORGAN SYSTEM オルガン記号	NEEDLE SYSTEM 針記号	ORGAN SYSTEM オルガン記号	NEEDLE SYSTEM 針記号	ORGAN SYSTEM オルガン記号
216×7	CY×7	328S	DD×2S	500	LA×505	723	BS×723	797PCL	PF×134PCL
251	LW×3T LW×4T	332	DI×3	501(SC)	EB×755	727F	DF×3	797PCLS	PF×134PCL
251EL	LW×5T	332EXT LG	SM×332EXTLG	502 W&G	WG×64	750	EB×750	797PCR	PF×134PCR
251EU	LW×251EU	332LG	AR×332LG	505LG	LA×505	750(SC)	EB×750	797S	PF×134KS
251LG	LW×5T	332LGHKSP	SM×332LG	506LG	SG×506	755H	EB×755	797SUK	SG×1907
253	PH×253	332LL	DI×4	551	FL×2A	759	UY×121 DV×1	805LR	SM×805LR
253C	PH×1	332LLLG	AR×332LLG	555	FL×1A	793	DY×1	854	SM×854
253S	PH×253S	332LR	DI×4LR	556KH	PF×797	793LL	DY×2	854S	SH×1 SH-A25
254/2	PO×254	332P	DI×4LR	558	DO×558	794	DY×3	854SA	SH-K9
265	DP×438	339	LA×339	561/1	FL×1A	794D	DY×3D	934	TV×934
265-5EO	DP×2655EO	354	DP×1	561/2	FL×2A	794LL	DY×3LL	950	RE×1
265-5KK	DP×2655KK	367LR	TF×287LR	562	MT×562	794LR	DY×2LR	950SERV	RE×2
265-50EO	DP×265	367S	PYL×367S	563	TF×1 PF×34R	797	DP×5 DP×7 DP×134	971A	SM×971A
265KK	DP×438KK	376P	PF×34P	563LL	TF×2	797CL	PF×134CL	971B/1	DV×971B
275	WG×576	438	DP×438	563LR	TF×2LR	797CR	PF×134CR	981R	UO×155
284	DG×1	438-8EO	DP×2655EO	573N	NB×5	797D	PF×134D	1000	SM×1000
287LR	TF×287LR	438-8KK	DP×2655KK	576	WG×576	797DIA	DP×8	1032B(1)	DPN-1032B
287P	PF×34P	438-80EO	DP×265	578	WG×578	797EL	PF×134EL	1055K	DB-E19
287WH	DB×95	438KK	DP×438KK	581	LA×1617	797ER	PF×134ER	1065K	DB-K2
287WK	DB×287WKH DB-A20	438LL	DP×438LL	581R	UO×155	797KH	PF×797	1128	DA×9 DAX1
287WKH	DB×287WKH	438LR	DP×438LR	604FE	PYA-1	797KK	PF×134KK	1232F	DF×3
300	LW×5T	459R	EB×1567	621	DC×1 DC-N17	797KKLR	PF×134KKLR	1280	UY×128GAS
328	DD×1	470KA	PF×470KA	621D	DC×1072	797KKS	DP-F22	1286	DN×1 UY×143GS
328A	DD×328A	471	CD×471	660	CP×660	797LL	PF×134LL	1373H	SM×1373H
328LL	DD×2	490	EB×1	690LR	TF×287LR	797LR	PF×134LR	1435	MR-R9
328LR	DD×2LR	490F	EB×2	705KH	BK×705KH	797P	PF×134P	1441	LQ×3

NEEDLE SYSTEM 針記号	ORGAN SYSTEM オルガン記号	NEEDLE SYSTEM 針記号	ORGAN SYSTEM オルガン記号	NEEDLE SYSTEM 針記号	ORGAN SYSTEM オルガン記号	NEEDLE SYSTEM 針記号	ORGAN SYSTEM オルガン記号	NEEDLE SYSTEM 針記号	ORGAN SYSTEM オルガン記号
1442	TB×1 DB×95	1738KK	DB-N20	2134-35CR	DP×35CR	4118	SM×4118	MY1014	SM×1014A
1470	LA×505	1738KKER	DB×1738KKER	2134-35K	DP×35K	4463	SM×4463	MY1014A	SM×1014A
1567	EB×1567	1738LR	DB×F2	2134-35LL	DP×35LL	4463-35	UO×4463LG	MY1014B	SM×1014B
1571	PO×1	1738S	DB×F17	2134-35LR	DP×35LR	4463KK	UO×4463	MY1014D	FD×1014D
1617	LA×1617	1807	EB×755	2134-35P	DP×35P	4463KKD	UO×4463KKD	MY1023	DC×27
1617N	SM×1617N	1807D	EB×755	2134-35S	DP×35S	5640	DV×57	MY1023A	DC×1 DC-N17
1620	PYA-1	1875	MR-R9	2134-35VR	DP×35VR	16031×1	FV×1	MY1033	UO×106G
1628	DV×1 UY×121	1886	DC×27	2134-85	DP×85	37984	LW×1T	MY1040	UY×128GAS
1645	TI×15	1886DC	DC×1072	2134-85CL	DP×85CL	B-26	RM×26	MY1042	UO×126G
1647	TB×1	1886KK	DM×13	2134-85CR	DP×85CR	B-27	DC×27	MY1043	UO×106G
1661	TQ×1 LQ×1	1906	SG×1906	2140BE	LW×6T LW×2T	B-27FM-B	RM×27FMB	MY1044	UY×128GAS
1661ELG	TQ×9	1910	SM×1910	2165	FO×9	B-29	RM×29	MY1072	DC×1072
1661LG	TQ×3 LQ×3	1958	MR-R9	2167	DP×17	B-63	DV×63 DV-K28	MY1151	TL×5
1669	LW×251EU	1985	TQ×1	2186TP	LW-C5	B-64	TV×64	MY1517	TL×7
1669E	LW×1669E	1987	TQ×9	2281	LA×2281	B-67	SM×67	SH×1 KK	SH×1
1669E EO	LW×1669E	2000A	DPN-2000A	2331	EB×1	B-134	PF×134KK	SY1001	AI×1
1682DI	TI×6	2018	TQ×3	2331F	EB×2	B-155	BB×155	SY1111	DH×1
1682DIA	TI×6	2019	FL×1A	2331F EXT.LG	EB×3LG	C-100-S	BC×100	SY1141	TK×3
1711H	KJ×3	2020	FL×2A	2331FLG	EB×3	D-5	BC×5	SY1202	YM×1
1715	LW×251EU	2077	TF×63	2669E	LW×1669E	DB×K5 KK	DB×N19	SY1225	DC×1 DC-N17
1715E	LW×1669E	2091	TQ×7	3140TP	LW×2T LW×6T	L83	SH×L83	SY1230	DC×5
1715F	LW×3T LW×4T	2091K	TQ×7	3201	LQ×5	L83 TOP	SH×L83	SY1241	DM×1
1717TP	LW×1T	2091KK	TQ-N14	3207	SM×3207	MY1001	DV×1 UY×121	SY1246	DM×13
1738	DB×1738	2109	AV×1	3207CR	SM×3207CR	MY1002	UO×106G	SY1261	TL×1
1738A	DB×95	2134-35(R)	DP×35R	3669E	LW×1669E	MY1002A	TV×7	SY1265	TL×7
1738EL	DB-P4	2134-35CL	DP×35CL	4117	SM×4117	MY1013	DN×1 UY×143GS	SY1291	TL×5

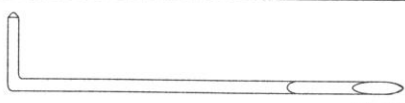
NEEDLE SYSTEM 針記号	ORGAN SYSTEM オルガン記号	NEEDLE SYSTEM 針記号	ORGAN SYSTEM オルガン記号	NEEDLE SYSTEM 針記号	ORGAN SYSTEM オルガン記号	NEEDLE SYSTEM 針記号	ORGAN SYSTEM オルガン記号	NEEDLE SYSTEM 針記号	ORGAN SYSTEM オルガン記号
SY1315	DA×1 DA×9	SY1906	SG×1906	SY2175	TF×4	SY3510	DV×1 UY×121	SY4961	DD×2LR
SY1361	DA×1 DA×9	SY1907	SG×1907	SY2220	TF×6	SY3516	DV×43	SY4968	DD×2S
SY1413	DO×5	SY1955	DP×5	SY2221	PF×34LLCR	SY3518	DV×47	SY5011	CY×1
SY1431	UY×154GAS	SY1963	SG×1963	SY2254	DB×1	SY3650	TV×3	SY5021	CY×7
SY1435	UY×8454	SY1965	SG×1965	SY2270	DB×1	SY3651	TV×3	SY5060	DR×2
SY1451	DP×1	SY1969	DP×39	SY2538	UY×158GJS	SY3690	LW×3T LW×4T	SY5068	DR×4 UO×1970
SY1496	NB×5	SY1981	PF×134D	SY2774	TV×1	SY3741	DI×3	SY5211	DY×1
SY1515	DB×95	SY1984	PF×134LR	SY2776	TV×7	SY3750	DI×4	SY5213	DY×3
SY1526	DL×1	SY1987	DP×8	SY2793	TV×25	SY3751	DI×4LR	SY5240	DY×2
SY1602	PV×5	SY1988	PF×134P	SY2851	TQ×1	SY3752	DI×4LR	SY5242	DY×2DIA
SY1610	PV×7	SY1989	DP×8	SY2901	YS×1	SY3757	DI×4LR	SY5250	DY×3LL
SY1627	LQ×3	SY1991	PF×134LL	SY2925	AV×1	SY3861	TF×63	SY5253	DY×2LR
SY1628	LQ×5	SY1992	PF×134KS	SY3005	DJ×259	SY4021	NQ×1	SY5901	PH×1
SY1629	LQ×7	SY2020	HA×1 HA×130	SY3027	FV×1	SY4051	TQ×3	SY5925	PH×253
SY1653	TI×3	SY2031	HA×1	SY3048	BQ×1	SY4110	TV×5	SY5926	PH×253S
SY1660	TI×15	SY2033	HA×1LL	SY3049	BQ×3	SY4112	DV×59	SY6050	WG×64
SY1666	TI×21	SY2034	HA×1LR	SY3060	TF×99	SY4151	TV×5	SY6060	UO×155
SY1677	DF×5	SY2047	TF×1 PF×34R	SY3201	DG×1	SY4261	DN×1 UY×143GS	SY6110	RM×26
SY1696	DP×39	SY2054	SL×75	SY3260	DV×57	SY4301	KJ×3	SY6120	DC×27
SY1710	TI×6	SY2055	TB×1	SY3270	DV×40SP	SY4401	EE×1	SY6121	RM×27FMB
SY1713	TI×2	SY2078	TF×F8	SY3303	FO×3	SY4531	TQ×7	SY6125	RM×29
SY1794	DF×3	SY2083	PF×34P	SY3305	FO×9	SY4538	TQ×9	SY6175	DC×1072
SY1901	DP×5 DP×134	SY2087	TF×2LR	SY3355	DP×17	SY4631	TQ×13	SY6200	MR-R9
SY1902	CP×1	SY2088	TF×2	SY3370	DP×16N	SY4804	DY×23	SY6235	UY×183GNS
SY1903	DP×5 DP×7 DP×134	SY2170	PF×34CL	SY3371	DP×16	SY4950	DD×1	SY6236	UO×183G
SY1905	DP×5 DP×7 DP×134	SY2174	TF×4	SY3381	DP×16	SY4960	DD×2	SY6270	PF×133R

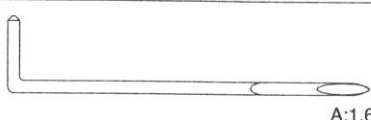



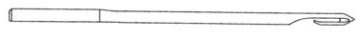





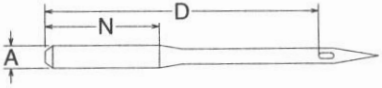









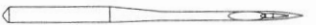

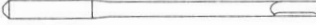









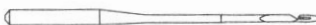

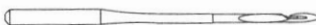

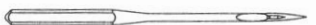
NEEDLE SYSTEM 針記号	ORGAN SYSTEM オルガン記号	NEEDLE SYSTEM 針記号	ORGAN SYSTEM オルガン記号	NEEDLE SYSTEM 針記号	ORGAN SYSTEM オルガン記号	NEEDLE SYSTEM 針記号	ORGAN SYSTEM オルガン記号	NEEDLE SYSTEM 針記号	ORGAN SYSTEM オルガン記号
SY6310	WG×576	SY6780	UO×150G	SY6986	FL×2A	SY7255	SM×1014A	SY7556	MT×190K
SY6335	SM×1910	SY6788	SG×1907	SY7000	LA×339	SY7256	SM×1014B	SY7585	TQ-N14
SY6365	MT×562	SY6790	DP×5 DP×7 DP×134	SY7032	LW×1T	SY7279	DV×1 UY×121	SY7600	AR×332LG
SY6371	SM×1617N	SY6791	PF×134LR	SY7033	LW-C5	SY7284	UY×121GBS	SY7601	AR×332LLG
SY6430	UY×154GBS	SY6793	PF×134PCL	SY7045	TV×64	SY7285	UO×126G	SY7604	DU×1
SY6431	UY×154GCS	SY6794	PF×134PCR	SY7060	FL×118A	SY7292	UY×128GAS	SY7606	LA×88
SY6432	UY×154GDS	SY6795	PF×797	SY7061	FL×118GBS	SY7295	UY×128GLS	SY7607	DU×2LR
SY6443	SM×35M	SY6796	PF×134EL	SY7065	UO×106G	SY7297	UY×121	SY7610	US×175H
SY6455	LA×2281	SY6797	PF×134ER	SY7068	UO×106G	SY7298	UO×130G	SY7615	LA×215
SY6480	EB×755	SY6799	PF×134PCL	SY7080	UO×108G	SY7299	UY×130GHS	SY7660	EB×1
SY6482	EB×750	SY6801	PF×134P	SY7086	UY×110GAS	SY7302	UY×133GS	SY7661	EB×2
SY6505	WG×578	SY6802	PF×134KS	SY7090	UO×113GS	SY7330	PF×470KA	SY7680	PYA-1
SY6520	EB×1567	SY6804	PF×134VR	SY7152	TV×934	SY7360	LW×1669E	SY7710	RE×1
SY6632	TF×287LR	SY6805	PF×134LL	SY7185	UO×163GAS	SY7380	DV×63 DV-K28	SY7713	SG×7713
SY6633	DB-A20 DB×287WKH	SY6806	PF×134LR	SY7210	LA×505	SY7395	LW×2T LW×6T	SY7715	UO×1975
SY6634	DB×287WKH	SY6807	PF×134D	SY7225	DP×35R	SY7396	LW×2T LW×6T	SY7720	SM×1000
SY6641	SM×3207CR	SY6809	DP×2655EO	SY7226	DP×35K	SY7425	LW×5T	SY7873	DPN-1032B
SY6710	BK×705KH	SY6811	PF×134LL	SY7227	DP×35LR	SY7430	LA×81	SY7875	DPN-1032B
SY6750	BB×155	SY6830	PF×34R TF×1	SY7228	DP×35S	SY7431	LA×81LR	SY7876	DPN-2000A
SY6758	DP×F22	SY6832	TF×2LR	SY7229	DP×35VR	SY7440	SG×506	SY8122	DP×438
SY6759	PF×134KK	SY6881	DB×1738KKER	SY7234	DP×35P	SY7449	SG×506	SY8358	DC×3
SY6760	PF×134KKLR	SY6935	UO×180G	SY7235	SM×805LR	SY7475	UO×147GA	SY8694	UO×4463
SY6761	PF×134KKPCL	SY6936	UY×180GXS	SY7237	DP×35LL	SY7505	SH×1	SY8699	SG×1907
SY6769	SM×1373H	SY6960	CP×1	SY7240	UO×4463LG	SY7525	SH×3	SY8703	DP×265
SY6777	PF×134CL	SY6965	PO×254	SY7242	DV×971B	SY7530	SM×854	SY8724	TQ×1
SY6778	PF×134CR	SY6985	FL×1A	SY7253	LW×251EU	SY7555	MT×190	SY8725	LA×505

NEEDLE SYSTEM 針記号	ORGAN SYSTEM オルガン記号	NEEDLE SYSTEM 針記号	ORGAN SYSTEM オルガン記号	NEEDLE SYSTEM 針記号	ORGAN SYSTEM オルガン記号	NEEDLE SYSTEM 針記号	ORGAN SYSTEM オルガン記号	NEEDLE SYSTEM 針記号	ORGAN SYSTEM オルガン記号
SY8727	TQ×3	UY128GS	UY×128GAS	UY183GS	UO×183G				
SY8728	TQ×7	UY130GHS	UY×130GHS	UY183GXS	UY×183GNS				
SY8745	EB×3	UY130GS	UO×130G	UY183GYS	UO×183G				
SY8763	DP×438KK	UY133GS	UY×133GS	UY1970A	UO×1970A				
SY8780	LA×1617	UY143GS	DN×1 UY×143GS	UY1970GS	DR×4 UO×1970				
UY101GS	UO×106G	UY147GS	UO×147GA	UY1975GS	UO×1975				
UY106GKS	UO×106G	UY150GAS	UO×150G	UY8023GS	SM×1014A				
UY106GS	UO×106G	UY150GS	UO×150G	UY8454GHS	UN×154 UY×8454				
UY108GHS	UO×108G	UY154GAS	UY×154GAS	UY8454GS	UY×8454				
UY108GKS	UO×108G	UY154GBS	UY×154GBS	UY9848GS	UO×1975				
UY108GS	UO×108G	UY154GCS	UY×154GCS	UY9854GS	UO×9854				
UY110GAS	UY×110GAS	UY154GDS	UY×154GDS	UY9858G	UY×9858G				
UY113GS	UO×113GS	UY155GAS	UO×155						
UY118GAS	FL×118A	UY158GJS	UY×158GJS						
UY118GBS	FL×118GBS	UY163GAS	UO×180G						
UY118GKS	FL×118GCS	UY163GS	UO×180G						
UY120GS	UO×108G	UY180GLS	UY×180GXS						
UY121GBS	UY×121GBS	UY180GPS	UO×180G						
UY121GHS	DV×1	UY180GS	UO×180G						
UY121GS	DV×1 UY×121	UY180GUS	UY×180GXS						
UY121GUS	UY×121GUS	UY180GVS	UY×180GVS						
UY124GS	TV×3	UY180GXS	UY×180GXS						
UY126GS	UO×126G UY×121	UY180GYS	UO×180G						
UY128GAS	UY×128GAS	UY183GHS	UY×183GNS						
UY128GHS	UY×128GLS	UY183GNS	UY×180GNS						
UY128GLS	UY×128GLS	UY183GPS	UO×183G						

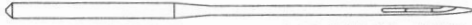

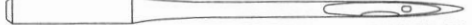









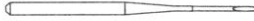



















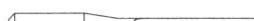

SYSTEM 記号	POINT 先端	NEEDLE PHOTO 針イメージ図	NEEDLE SIZES 番手	REMARKS 備考欄
				
AR X 332LLG		 A:1.98 D:48.50 N:18.00	<b>18 19 21 22 23 24</b> 110 120 130 140 160 180	八方送り用
AV X 1		 A:2.00 D:37.40 N:14.50	<b>14 16 18 20 21</b> 90 100 110 125 130	overedging for tent, etc テント等の縁巻用
BB X 155		 A:2.00 D:33.70 N:10.00	<b>12 14 16 18 19 21</b> 80 90 100 110 120 130	sideseam of sweater, etc セーター等の脇縫用
BC X 5		 A:2.00 D:38.90 N:12.00	<b>25</b> 200	bag closing 袋縫い
BC X 5R		 A:2.00 D:38.90 N:12.00	<b>25</b> 200	bag closing 袋口縫用
BC X 100		 A:3.15 D:64.70 N:19.00	<b>27</b> 250	bag closing 袋口縫用
BC X 100R		 A:3.15 D:64.70 N:19.00	<b>27</b> 250	bag closing 袋口縫用
BL X 1		 A:1.62 D:33.80 N:13.50	<b>9 10 11 12 14 16</b> 65 70 75 80 90 100	for babylock ベビーロック職業用
BOY - 3		 A:1.62 D:51.50 N:25.00	<b>22</b> 140	for book binding (sewing) 製本用縫針
BOY - 7		 A:1.62 D:37.40 N:16.00	<b>23</b> 160	for book binding (sewing) 製本用縫針
BOZ - 1		 A:1.50~1.80 N:7.00	<b>150 160 180</b>	for book binding (hook) 製本用掛け針
BOZ - 3		 A:1.60 N:7.00	<b>160</b>	for book binding (hook) 製本用掛け針
BOZ - 12		 A:1.90 N:14.00	<b>150</b>	for book binding (hook) 製本用掛け針
BOZ - 13		 A:1.90 D:44.10 N:12.00	<b>150</b>	

※ALTHOUGH NOT DESCRIBED ABOVE, WE CAN PROVIDE A FULL ASSORTMENT OF BALL POINT NEEDLE.

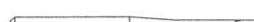









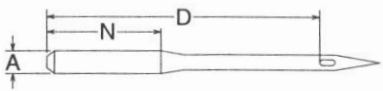



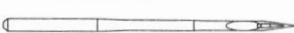

















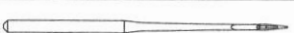





SYSTEM 記号	POINT 先端	NEEDLE PHOTO 針イメージ図 	NEEDLE SIZES 番手	REMARKS 備考欄
BQ × 1		 A:1.62 D:37.20 N:15.00	<b>8 9 10 11 12 13 14 16 18 19 20 21 22 23</b> 60 65 70 75 80 85 90 100 110 120 125 130 140 160	button sewing ボタン付け
CD × 471		 A:1.75 D:37.00 N:11.50	<b>14 16 18 20</b> 90 100 110 125	for chandler sewing machine チャンドラーミシン用
CP × 1		 A:2.02 D:34.50 N:18.00	<b>14 16 18 19 21 22</b> 90 100 110 120 130 140	pin-point sewing 星飾り縫い・ピンポイント用
CP × 1J		 A:2.02 D:34.50 N:18.00	<b>14 16 18 19 21 22</b> 90 100 110 120 130 140	
CP × 2		 A:2.02 D:34.50 N:14.00	<b>14 16 18 19 21 22 23</b> 90 100 110 120 130 140 160	pin-point sewing 星飾り縫い・ピンポイント用
CP × 5		 A:2.48 D:43.50 N:12.00	<b>18 21 23 25 27</b> 110 130 160 200 250	for shoe 製靴用
CP × 5VR		 A:2.48 D:43.50 N:12.00	<b>25 27</b> 200 250	
CP × 12		 A:2.02 N:18.00	<b>11 12 14 16 18 19 20 21 22 23</b> 75 80 90 100 110 120 125 130 140 160	pin-point sewing 星飾り縫い・ピンポイント用
CP × 12J		 A:2.02 N:18.00	<b>19 20 21 22 23</b> 120 125 130 140 160	
CP × 13		 A:2.02 N:14.00	<b>9 11 12 14 16 18 19 20 21 22 23</b> 65 75 80 90 100 110 120 125 130 140 160	pin-point sewing 星飾り縫い・ピンポイント用
CP × 17		 A:2.02 N:12.50	<b>11 14 16 18 19 21</b> 75 90 100 110 120 130	pin-point sewing 星飾り縫い・ピンポイント用
CP × 170		 A:2.02 N:12.50	<b>14 16 18 19 21</b> 90 100 110 120 130	pin-point sewing 星飾り縫い・ピンポイント用
CP × 200		 A:2.02 D:34.50 N:14.00	<b>14 16 18 19</b> 90 100 110 120	pin-point sewing 星飾り縫い・ピンポイント用
CP × 660		 A:2.00 N:11.50	<b>12 14 16 18 19 21 22 23 24 25</b> 80 90 100 110 120 130 140 160 180 200	complete linking コンプレットリンク用
CY × 1		 A:2.02~2.50 D:52.60~52.20 N:22.00~17.50	<b>16 18 19 20 21 22 23 24 25 26 27 28</b> 100 110 120 125 130 140 160 180 200 230 250 280	for thicker material (tent, etc) テントズック等厚物用
CY × 7		 A:3.52 D:52.20 N:16.50	<b>19 22 23 24 25 26 27 28 29 30</b> 120 140 160 180 200 230 250 280 300 330	for canvas products (rucksack, etc) 袋ザック等 キャンバス製品用
DA × 1		 A:1.62 D:29.60 N:14.50	<b>7 8 9 10 11 12 13 14 16 18 19 20 21 22</b> 55 60 65 70 75 80 85 90 100 110 120 125 130 140	lock stitch 本縫い
DA × 1KN		 A:1.62 D:29.60 N:13.50	<b>8 9 10 11</b> 60 65 70 75	for knitted fabric ニット用



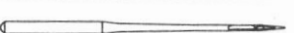

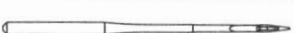

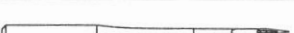



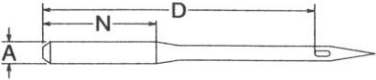

























※ALTHOUGH NOT DESCRIBED ABOVE, WE CAN PROVIDE A FULL ASSORTMENT OF BALL POINT NEEDLE.

SYSTEM 記号	POINT 先端	NEEDLE PHOTO 針イメージ図	NEEDLE SIZES 番手	REMARKS 備考欄
DA × 9		 A:1.62 D:29.70 N:13.50	<b>7 8 9 10 11 12 13 14 16 18 20 21</b> 55 60 65 70 75 80 85 90 100 110 125 130	lock stitch 本縫い
DB × 1		 A:1.62~2.02 D:33.80 N:16.00~10.50	<b>7 8 9 10 11 12 13 14 16 18 19 20 21 22 22½ 23 24 25</b> 55 60 65 70 75 80 85 90 100 110 120 125 130 140 150 160 180 200	lock stitch 本縫い
DB × 1NS		 A:1.62 D:33.80 N:16.00	<b>8 9 10 11 12 14</b> 60 65 70 75 80 90	for new synthetic material 新合繊用
DB × 1-NY2		 A:1.62~1.90 D:33.80 N:16.00~12.50	<b>9 10 11 12 14 16 18 19</b> 65 70 75 80 90 100 110 120	for avoiding skipped stitches 目飛び対策針
DB × 1HS		 A:1.62~2.02 D:33.80 N:16.00~10.50	<b>9 11 14 16 18 19 21 22 23</b> 65 75 90 100 110 120 130 140 160	heatproof needle 熱対策針
DB × 1KN		 A:1.62 D:33.80 N:16.00	<b>8 9 10 11 12 14</b> 60 65 70 75 80 90	for knitted fabric ニット用
DB × 1KNLE		 A:1.62 D:33.80 N:16.00	<b>9 10 11 12</b> 65 70 75 80	decorative stitch for knit ニットステッチ用
DB × 1PR		 A:1.62 D:33.80 N:16.00	<b>10 11</b> 70 75	for printed fabric プリント生地用
DB × 1SF		 A:1.62 D:33.80 N:16.00	<b>8 9 10 11</b> 60 65 70 75	for super fine gauge knitted fabric 超ファインゲージニット用
DB × 1SGR		 A:1.62 D:33.80 N:16.00	<b>11 12 14 16</b> 75 80 90 100	DB × 1 with twisted groove DB × 1の溝ひねり針
DB × 1ST		 A:2.02 D:33.80 N:12.50~11.50	<b>20 22</b> 125 140	decorative stitch 飾りステッチ用
DB × 3ST		 A:2.02 D:33.80 N:10.00	<b>11 14 16 18 20 22</b> 75 90 100 110 125 140	decorative stitch 飾りステッチ用
DB × 5ST		 A:1.62 D:33.80 N:16.00~11.50	<b>16 20 22</b> 100 125 140	decorative stitch 飾りステッチ用
DB × 7ST		 A:1.62 D:33.00 N:16.00	<b>9 11 12 14 16 18</b> 65 75 80 90 100 110	embroidery stitch 刺繍用
DB × 9ST		 A:1.62 D:33.80 N:16.00	<b>9 11 14 16 18</b> 65 75 90 100 110	decorative stitch 飾りステッチ用
DB × 95		 A:1.62 D:33.80 N:13.50	<b>8 9 10 11 12 13 14 16 17 18 19 20 21 22 23 24</b> 60 65 70 75 80 85 90 100 105 110 120 125 130 140 160 180	lock stitch (single-swaged blade) 本縫い用一段伸線
DB × 130B		 A:1.62 D:33.90 N:13.50	<b>10 11 12 14 16 18 19 20 21</b> 70 75 80 90 100 110 120 125 130	lock stitch, bartacking 本縫門止用
DB × 287WKH		 A:1.62 D:33.90 N:16.00	<b>6 7 8 9 10 11 12 13 14 16 18 19 21</b> 50 55 60 65 70 75 80 85 90 100 110 120 130	embroidery stitch 刺繍用











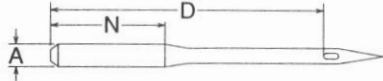





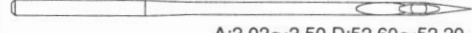

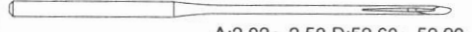

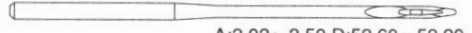

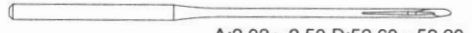

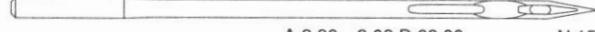

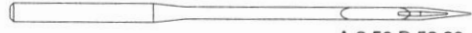









※ALTHOUGH NOT DESCRIBED ABOVE, WE CAN PROVIDE A FULL ASSORTMENT OF BALL POINT NEEDLE.

SYSTEM 記号	POINT 先端	NEEDLE PHOTO 針イメージ図 	NEEDLE SIZES 番手	REMARKS 備考欄
DB × 1738		 A:1.62~2.02 D:33.80 N:16.00~11.50	8 9 10 11 12 13 14 16 18 19 20 21 22 23 24 60 65 70 75 80 85 90 100 110 120 125 130 140 160 180	lock stitch 本縫い
DB × A20		 A:1.62 D:33.80 N:12.50~10.50	19 20 21 22 23 120 125 130 140 160	(shank diameter = 1.62mm) A寸=1.62mm
DB - C85		 A:1.62 D:33.80 N:16.00	9 10 11 65 70 75	DB × 1KN with flat shank DB × 1KN の平取針
DB - C86		 A:1.62 D:33.80 N:16.00	9 10 11 14 65 70 75 90	DB × 1 with flat shank DB × 1 の平取針
DB - C98		 A:1.62 D:33.80 N:16.00	14 16 90 100	DB × 1 with flat shank angle of 28° on right DB × 1 の平取角度右28°
DB × F2		 A:1.62~2.02 D:33.80 N:16.00~10.50	9 11 12 13 14 16 18 19 20 21 22 23 24 25 65 75 80 85 90 100 110 120 125 130 140 160 180 200	for leather 皮革用
DB × F17		 A:1.62~1.90 D:33.80 N:16.00~12.50	8 9 10 11 12 14 16 18 19 60 65 70 75 80 90 100 110 120	for leather 皮革用
DB × K5		 A:1.62~1.90 D:33.80 N:16.00~12.50	8 9 10 11 12 13 14 16 18 19 60 65 70 75 80 85 90 100 110 120	embroidery stitch 刺繍用
DB × K5-NY		 A:1.62 D:33.80 N:16.00	8 9 10 11 12 13 14 60 65 70 75 80 85 90	DB × K5 with reinforced blade 強度対策針
DB × K5Q1		 A:1.62 D:33.80 N:16.00	8 9 10 11 12 14 60 65 70 75 80 90	for multi-head embroidery machine 刺繍用
DB × K5Q1 - NY		 A:1.62 D:33.80 N:16.50	9 10 11 12 14 65 70 75 80 90	DB × K5Q1 with reinforced blade 刺繍用強度対策針
DB × K5Q2 - NY		 A:1.62 D:33.80 N:13.50	9 10 11 12 14 65 70 75 80 90	for cylindrical frame, thicker material 刺繍 厚物、円筒枠用
DB × K5 - YORI		 A:1.62 D:33.80 N:16.50	8 9 11 60 65 75	for multi-head embroidery machine 刺繍用
DB × K5Z1		 A:1.62 D:33.80 N:16.00	8 9 10 11 12 14 60 65 70 75 80 90	for multi-head embroidery machine 刺繍用
DB × K5Z1 - NY		 A:1.62 D:33.80 N:16.50	9 10 11 12 14 65 70 75 80 90	DB × K5Z1 with reinforced blade 刺繍用強度対策針
DB × K5Z2 - NY		 A:1.62 D:33.80 N:13.50	9 10 11 12 14 65 70 75 80 90	for cylindrical frame, thicker material 刺繍 厚物、円筒枠用
DB - N19		 A:1.62 D:33.80 N:13.50	9 10 11 12 14 65 70 75 80 90	DB × K5 with shorter shank DB × K5のN寸短
DB - N20		 A:1.62 D:33.80 N:12.50	11 14 16 75 90 100	for thicker material DB×1 with shorter shank 厚地用 DB × 1のN寸短

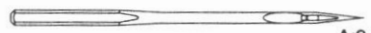

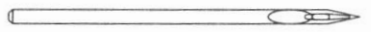







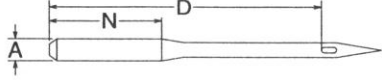





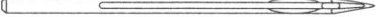



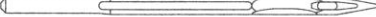















※ALTHOUGH NOT DESCRIBED ABOVE, WE CAN PROVIDE A FULL ASSORTMENT OF BALL POINT NEEDLE.

SYSTEM 記号	POINT 先端	NEEDLE PHOTO 針イメージ図		NEEDLE SIZES 番手	REMARKS 備考欄	
						
DC × 1			A:2.02 D:28.60	N:10.00	6 7 8 9 10 11 12 13 14 16 18 19 20 21 22 23 24 25 50 55 60 65 70 75 80 85 90 100 110 120 125 130 140 160 180 200	overlock オーバーロック用 ~#11=J ball
DC × 1NS			A:2.02 D:28.60	N:10.00	8 9 10 11 12 60 65 70 75 80	for new synthetic material 新合繊用
DC × 1F			A:2.02 D:28.60	N:10.00	9 11 12 14 16 18 65 75 80 90 100 110	babylock (DC × 1 with flat shank) ベビーロック用 DC × 1の平取針
DC × 1KN			A:2.02 D:28.60	N:10.00	8 9 10 11 12 14 60 65 70 75 80 90	for knitted fabric ニット用
DC × 1SF			A:2.02 D:28.60	N:10.00	9 10 11 65 70 75	for super fine gauge knitted fabric 超ファインゲージニット用
DC × 3			A:1.22 D:28.50	N:13.00	6 7 8 9 10 11 12 13 14 16 18 19 20 21 22 50 55 60 65 70 75 80 85 90 100 110 120 125 130 140	blind stitch, 2-needles overlock まつり縫い用 2本針オーバーロック
DC × 3KN			A:1.22 D:28.60	N:13.00	9 10 11 65 70 75	for knitted fabric ニット用
DC × 5			A:2.02 D:28.60	N:10.50~10.00	14 16 18 19 20 21 22 23 90 100 110 120 125 130 140 160	overlock オーバーロック用
DC × 7			A:1.62 D:28.60	N:11.50	8 9 11 60 65 70	interlock インターロック用
DC × 27			A:2.02 D:28.60	N:10.00	6 7 8 9 10 11 12 13 14 16 18 19 20 21 22 23 24 50 55 60 65 70 75 80 85 90 100 110 120 125 130 140 160 180	overlock オーバーロック用 ~#11=J ball
DC × 27HS			A:2.02 D:28.60	N:10.00	11 75	heatproof needle 熱対策針
DC × 27LE			A:2.02 D:28.60	N:10.00	11 14 16 75 90 100	DC × 27 with larger needle-eye DC × 27の糸穴大
DC - C47			A:2.02 D:28.60	N:10.00	9 10 11 12 13 16 18 65 70 75 80 85 100 110	flat shank on both sides 両面平取
DC - C87			A:2.02 D:28.60	N:10.00	9 10 11 12 14 65 70 75 80 90	babylock DC × 1KN with flat shank ベビーロック用 DC × 1KNの平取針
DC - J27			A:2.02 D:28.60	N:10.00	9 10 11 14 16 65 70 75 90 100	DC × 27 without rear groove DC × 27の裏溝無
DC - K32			A:2.02 D:28.60	N:13.00	10 70	DC-N17 with larger needle-eye DC-N17の糸穴大
DC - N17			A:2.02 D:28.60	N:13.00	6 7 8 9 10 11 12 13 14 16 18 19 20 21 22 50 55 60 65 70 75 80 85 90 100 110 120 125 130 140	shank length = 13mm DC × 1 N寸=13mm
DC - N17SF			A:2.02 D:28.60	N:13.00	9 10 65 70	for super fine gauge knitted fabric 超ファインゲージニット用











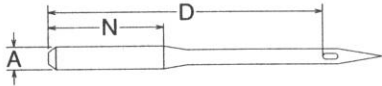

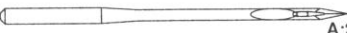















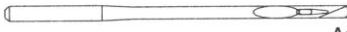







※ALTHOUGH NOT DESCRIBED ABOVE, WE CAN PROVIDE A FULL ASSORTMENT OF BALL POINT NEEDLE.

SYSTEM 記号	POINT 先端	NEEDLE PHOTO 針イメージ図	NEEDLE SIZES 番手	REMARKS 備考欄
				
DC - N25		 A:2.02 D:28.60 N:11.50	<b>7 8 9 10 11</b> 55 60 65 70 75	shank length = 11.50mm DC × 1 N寸=11.50mm
DC - N25SF		 A:2.02 D:28.60 N:11.50	<b>9</b> 65	for super fine gauge knitted fabric 超ファインゲージニット用
DD × 1		 A:2.02~2.50 D:52.60~52.20 N:22.00~17.50	<b>16 18 19 20 21 22 22½ 23 23½ 24 24½ 25 26 27 28 29</b> 100 110 120 125 130 140 150 160 170 180 190 200 230 250 280 300	for heavy material (leather, sail, etc) 皮革、帆布等厚物縫用
DD × 2		 A:2.02~2.50 D:52.60~52.20 N:22.00~17.50	<b>16 18 19 21 22 23 24 25 26 27 28 29</b> 100 110 120 130 140 160 180 200 230 250 280 300	for heavy material (leather, sail, etc) 皮革、帆布等厚物縫用
DD × 2S		 A:2.02~2.50 D:52.60~52.20 N:22.00~17.50	<b>18 19 21 22 23 24 25 26 27</b> 110 120 130 140 160 180 200 230 250	for heavy material (leather, sail, etc) 皮革、帆布等厚物縫用
DD × 2LR		 A:2.02~2.50 D:52.60~52.20 N:21.00~17.50	<b>14 16 18 19 21 22 23 24 25 26 27 28 29</b> 90 100 110 120 130 140 160 180 200 230 250 280 300	for heavy material (leather, sail, etc) 皮革、帆布等厚物縫用
DD - G26		 A:2.80~3.02 D:68.00 N:15.00	<b>28 29 30</b> 280 300 330	with scarf エグリ付き
DD - H14		 A:2.50 D:52.20 N:19.00	<b>23 24 25</b> 160 180 200	with larger scarf エグリ大
DF × 3		 A:1.75 D:33.90 N:13.00	<b>9 10 11 12 14 16</b> 65 70 75 80 90 100	edge decorative seaming (shirts, handkerchief, etc) シャツ・ハンカチ等縁飾り縫用
DF - M20		 A:1.75 D:33.90 N:13.00	<b>10 11 12 14</b> 70 75 80 90	DF × 3 with scarf DF × 3のエグリ付き
DH × 1		 A:2.02 D:28.20 N:13.50~11.50	<b>7 8 9 10 11 12 14 16 18 19 20 21 22</b> 55 60 65 70 75 80 90 100 110 120 125 130 140	edge seaming 帽子やメリヤス地の端縫用
DI × 3		 A:2.00 D:39.20~39.00 N:14.50	<b>12 14 16 18 19 20 21 22 22½ 23 24 25 26</b> 80 90 100 110 120 125 130 140 150 160 180 200 230	for shoe, bag, etc 靴、袋物縫用
DI × 4		 A:2.00 D:39.20~38.60 N:14.50	<b>14 16 18 19 20 21 22 23 24 25</b> 90 100 110 120 125 130 140 160 180 200	for leather, shoe 皮革、靴縫用
DI × 4LR		 A:2.00 D:39.20 N:14.50	<b>12 14 16 18 19 20 21 22 23</b> 80 90 100 110 120 125 130 140 160	for leather, shoe 皮革、靴縫用
DI - C78		 A:2.00 D:39.00 N:14.50	<b>22 23</b> 140 160	DI × 3 with flat shank DI × 3の平取針
DI - E36		 A:2.00	<b>25</b> 200	for heavy material (slippers, etc) 極厚物スリッパ底縫用
DM × 1		 A:2.02 D:28.60 N:10.00	<b>6 7 8 9 10 11 12 13 14 16 18 19 20 21 22</b> 50 55 60 65 70 75 80 85 90 100 110 120 125 130 140	double chain-stitch for knitted glove, etc メリヤス手袋等二重環縫用
DM × 5		 A:2.02 D:30.50 N:13.50	<b>19 20 21 22 23 24 25</b> 120 125 130 140 160 180 200	overlock (with two scarfs) オーバーロック 2箇所えぐり

※ALTHOUGH NOT DESCRIBED ABOVE, WE CAN PROVIDE A FULL ASSORTMENT OF BALL POINT NEEDLE.

SYSTEM 記号	POINT 先端	NEEDLE PHOTO 針イメージ図 	NEEDLE SIZES 番手	REMARKS 備考欄
DM × 13		 A:2.02 D:28.60 N:8.00	<b>7 8 9 10 11 12 13 14 16 18 19 20 21 22 23 24</b> 55 60 65 70 75 80 85 90 100 110 120 125 130 140 160 180	interlock インターロック用 ~#11=J ball
DM × 13KN		 A:2.02 D:28.60 N:8.00	<b>9 10 11</b> 65 70 75	for knitted fabric ニット用
DN × 1		 A:2.00 D:42.40 N:14.50~13.00	<b>18 19 21 22 23 24 25 26 27</b> 110 120 130 140 160 180 200 230 250	bag closing (cement bag, etc) セメント袋口縫厚物用
DN × 1Q		 A:2.00 D:42.40 N:13.00	<b>25</b> 200	for heavy material (bag, etc) 袋厚物用
DN - H29		 A:2.00 D:42.00 N:14.50	<b>26</b> 230	
DO × 5		 A:2.02 D:31.30 N:10.00	<b>11 12 14 16 17 18 19 20 21 22</b> 75 80 90 100 105 110 120 125 130 140	eyelet buttonholing 鳩目穴かがり用
DO × 5 - NY		 A:2.02 D:31.30 N:10.00	<b>16 18 19</b> 100 110 120	DO × 5 with reinforced blade 強度対策針
DO × 558		 A:2.00 D:33.90 N:11.00	<b>10 11 12 14 16 18 19 21</b> 70 75 80 90 100 110 120 130	eyelet buttonholing 鳩目穴かがり用
DO × 558 - NY2		 A:2.00 D:33.90 N:11.00	<b>12 14 16 18 19</b> 80 90 100 110 120	for avoiding skipped stitches 目飛び対策針
DP × 1		 A:2.00 D:31.90 N:12.50~11.50	<b>8 9 10 11 12 13 14 16 18 19 20 21 22 22½ 23 24 25</b> 60 65 70 75 80 85 90 100 110 120 125 130 140 150 160 180 200	lock stitch 本縫い
DP × 5		 A:2.00 D:33.90 N:12.50~11.50	<b>6 7 8 9 10 11 12 13 14 16 18 19 20 21 22 22½ 23 23½ 24 25</b> 50 55 60 65 70 75 80 85 90 100 110 120 125 130 140 150 160 170 180 200	buttonholing, zig-zag sewing 穴かがり・千鳥縫用
DP × 5NS		 A:2.00 D:33.90 N:12.50	<b>8 9 10 11 12 14</b> 60 65 70 75 80 90	for new synthetic material 新合繊用
DP × 5KN		 A:2.00 D:33.90 N:12.50	<b>8 9 10 11 12</b> 60 65 70 75 80	for knitted fabric ニット用
DP × 5SF		 A:2.00 D:33.90 N:12.50	<b>9 10 11</b> 65 70 75	for super fine gauge knitted fabric 超ファインゲージニット用
DP × 5SGR		 A:2.00 D:33.90 N:12.50~11.50	<b>11 14 16</b> 75 90 100	with twisted groove 溝ひねり針
DP × 7		 A:2.00 D:33.90 N:11.00	<b>8 9 10 11 12 14 16 18 19 20 21 22 22½ 23 24 25</b> 60 65 70 75 80 90 100 110 120 125 130 140 150 160 180 200	chain stitch, basting 単環縫しつけ用
DP × 8		 A:2.00 D:33.90 N:14.50~11.50	<b>10 12 14 16 18 19 20 21 22 23 24</b> 70 80 90 100 110 120 125 130 140 160 180	for leather 皮革用
DP × 16		 A:2.00 D:39.00 N:13.50	<b>12 14 16 18 19 20 21 22 23 24 25</b> 80 90 100 110 120 125 130 140 160 180 200	for leather 皮革用

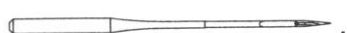
※ALTHOUGH NOT DESCRIBED ABOVE, WE CAN PROVIDE A FULL ASSORTMENT OF BALL POINT NEEDLE.

SYSTEM 記号	POINT 先端	NEEDLE PHOTO 針イメージ図	NEEDLE SIZES 番手	REMARKS 備考欄
				
DP × 16DIA		 A:2.00 D:39.00 N:13.50	<b>16 18 19 20 21 22 23 24 25</b> 100 110 120 125 130 140 160 180 200	for leather 皮革用
DP × 16LR		 A:2.00 D:39.00 N:13.50	<b>19 20 21 22 23 24</b> 120 125 130 140 160 180	for leather 皮革用
DP × 16N		 A:2.00 D:39.00 N:13.50	<b>20 21 22 23</b> 125 130 140 160	for leather 皮革用
DP × 17		 A:2.00 D:39.00 N:16.00~13.00	<b>9 10 11 12 13 14 15 16 18 19 20 21 22 23 24 25 26</b> 65 70 75 80 85 90 95 100 110 120 125 130 140 160 180 200 230	lock stitch for thicker material 本縫厚物用
DP × 17H		 A:2.00 D:39.00 N:13.00	<b>24 25 26</b> 180 200 230	DP × 17 with larger scarf DP × 17のエグリ大
DP × 17HS		 A:2.00 D:39.00 N:16.00~13.00	<b>11 18 20 21 22 23 24 25</b> 75 110 125 130 140 160 180 200	heatproof needle 熱対策針
DP × 17LE		 A:2.00 D:39.00 N:16.00~13.00	<b>14 16 18 19 21 22 23</b> 90 100 110 120 130 140 160	DP × 17 with larger needle-eye DP × 17の糸穴大
DP × 17NS		 A:2.00 D:39.00 N:16.00	<b>14</b> 90	
DP × 17LBR		 A:2.00 D:39.00 N:13.00	<b>23</b> 160	for leather 皮革用
DP × 17LR		 A:2.00 D:39.00 N:16.00~13.00	<b>14 16 18 19 20 21 22 23 24</b> 90 100 110 120 125 130 140 160 180	for leather 皮革用
DP × 17 - NY2		 A:2.00 D:39.00 N:16.00~13.00	<b>12 14 16 18 19 20 21 22 23</b> 80 90 100 110 120 125 130 140 160	for avoiding skipped stitches 目飛び対策針
DP × 17 - SK1		 A:2.00 D:39.00 N:16.00~13.50	<b>14 16 18 19 20 21 22 23 24 25</b> 90 100 110 120 125 130 140 160 180 200	
DP × 17S		 A:2.00 D:39.00 N:16.00~13.00	<b>14 16 18 19 20 21 22 23</b> 90 100 110 120 125 130 140 160	for leather 皮革用
DP × 17SF		 A:2.00 D:39.00 N:16.00	<b>9 10</b> 65 70	for super fine gauge knitted fabric 超ファインゲージニット用
DP × 17TQ		 A:2.00 D:39.00 N:13.00	<b>14 16 18 19 21 22 23</b> 90 100 110 120 130 140 160	for leather 皮革用
DP × 35CL		 A:2.00 D:38.20 N:13.50	<b>10 12 14 16 18 19 21 22 23</b> 70 80 90 100 110 120 130 140 160	welt seam, pocket seamer 本縫玉縁用 ポケットシーマー等
DP × 35CR		 A:2.00 D:38.20 N:13.50	<b>10 12 14 16 18 19 21 22 25</b> 70 80 90 100 110 120 130 140 200	welt seam, pocket seamer 本縫玉縁用 ポケットシーマー等
DP × 35D		 A:2.00 D:38.20 N:13.50	<b>14 16 18 19 20 21 22 22½ 23 24</b> 90 100 110 120 125 130 140 150 160 180	for leather 皮革用

※ALTHOUGH NOT DESCRIBED ABOVE. WE CAN PROVIDE A FULL ASSORTMENT OF BALL POINT NEEDLE.